



EN3230 Broadband Access Client Integrated Circuit

The EN3230 is Entropic's second generation c.LINK™ Access client integrated circuit, that leverages existing coaxial cable infrastructure, enabling a cost effective and easy to install client premise equipment solution (CPE). With a EN3230 based CPE the service providers can offer 100Mbps data and video networking services to residents within single family homes and MDUs (Multi Dwelling Units) with no new wires, and with no changes to the existing wiring.

Many international cable television service providers are racing to provide competitive broadband access solutions to compete with Telco VDSL deployments and to innovate by introducing new services like VOD and IPTV that require greater throughput. Until now this has been challenging as low cost coax based solutions have not been available outside the low performance DOCSIS architecture. However, with the availability of a deep fiber footprint and c.LINK Access on coax for the last few hundred meters, compelling high data rate services like VOD and IPTV can be offered by service providers.

Entropic's c.LINK chipset, the core technology behind the MoCA industry standard for home entertainment networking, has been adapted to support a star-based point to multi-point network topology necessary to provide high speed broadband access to homes and MDUs from FTTC and FTTB deployments. c.LINK Access brings many of the home networking benefits to the Broadband Access application including, low latency and jitter, full quality of service, and proven security.

Customers for EN3230 based products include Cable, Telco and Satellite Operators, Set-Top Box OEMs, Network Equipment OEMs and Consumer Electronics OEMs. The c.LINK technology has been adopted by a large customer base worldwide for its versatility and flexibility. The c.LINK technology allows a selection of broadcast frequencies from 800 MHz to 1500 MHz, which can be used to cascade multiple network channels to increase throughput and/or unit coverage, and also to ensure coexistence with existing cable, terrestrial and satellite service signals.

The complete c.LINK Access Solution is comprised of the EN3011 Access Network Controller chip and the new EN3230 Access client integrated circuit. The EN3011, in combination with the EN1011 RF integrated circuit, is used in devices at the point-of-entry to a building to create a single network controller for the building and to provide over 100 Mbps of broadband data to up to 31 CPE units. The EN3230 is used in combination with the EN1010 RFIC in customer premise equipment (CPEs), such as simple access points, home gateways or advanced routers.

The EN3230 is supported by the EN93230MDK (Manufacturing Development Kit), a complete box design for a low cost CPE solution based on the EN3230.

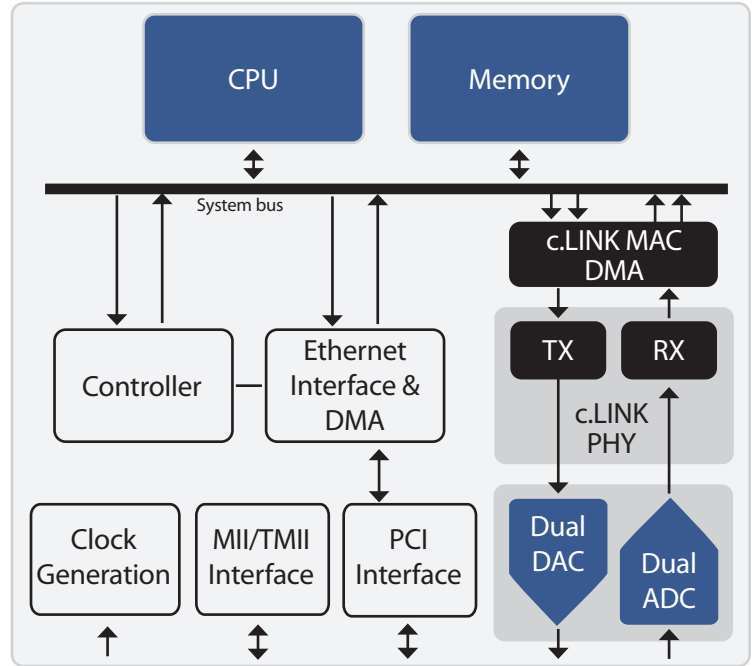

EN3230 Single Chip Cable Access IC Block Diagram

Applications

- Last 600 meters high speed data and video distribution including VOD and IPTV
- FTTP with coax distribution
- Client premise equipment
 - o Access point/gateway
 - o Ethernet to coax bridge or router
 - o IP set-top box and digital video recorder

Benefits

- No new wires or changes to existing wiring
 - o Video and data networking using existing coax cable and splitters
- Supports >100 Mbps to each subscriber
- Enables a managed and trusted network
- Enables tiered rate structuring
- Creates new revenue streams for service providers
- Simple and inexpensive installation and configuration
- Dramatic reduction in deployment costs

Features

- Network characteristics
 - o Data capacity per channel is > 120 Mbps (>600 Mbps for 5 channels)
 - o Point to multi-point configuration
 - o Support up to 31 clients per c.LINK network controller
 - o Constant-delay and low-latency network
 - o TDMA/TDD-fully coordinated MAC, no collisions
 - o Frequency scanning from 800 MHz to 1500 MHz for efficient bandwidth utilization
 - o SNMP support
 - o Extended distance support of up to 600 m
 - o Supports up to 5 channels on a single coax
- Bandwidth management
 - o Rate adaptation
 - o VLAN & multicast filtering support
 - o System upstream and downstream rate control
 - o Client node data rate limits and committed rates
 - o Support for IEEE 802.1p priorities
- Network security
 - o Hardware DES encryption for network privacy
 - o Network coordinator access control of the client nodes
- Single chip c.LINK controller for coax-based access networks
 - o MII industry standard, TMII and GMII interfaces
 - o 3.3 V I/O, PCI interface (3.3 V/5.0 V)
 - o > 250 Mbps data rate
 - o Integrated high speed ADC and DAC
 - o 1.2V, 1.8V, & 3.3V power supplies
 - o 19 mm x 19 mm 324-PBGA package
 - o IEEE 1149.1 standard access test port and boundary scan architecture support

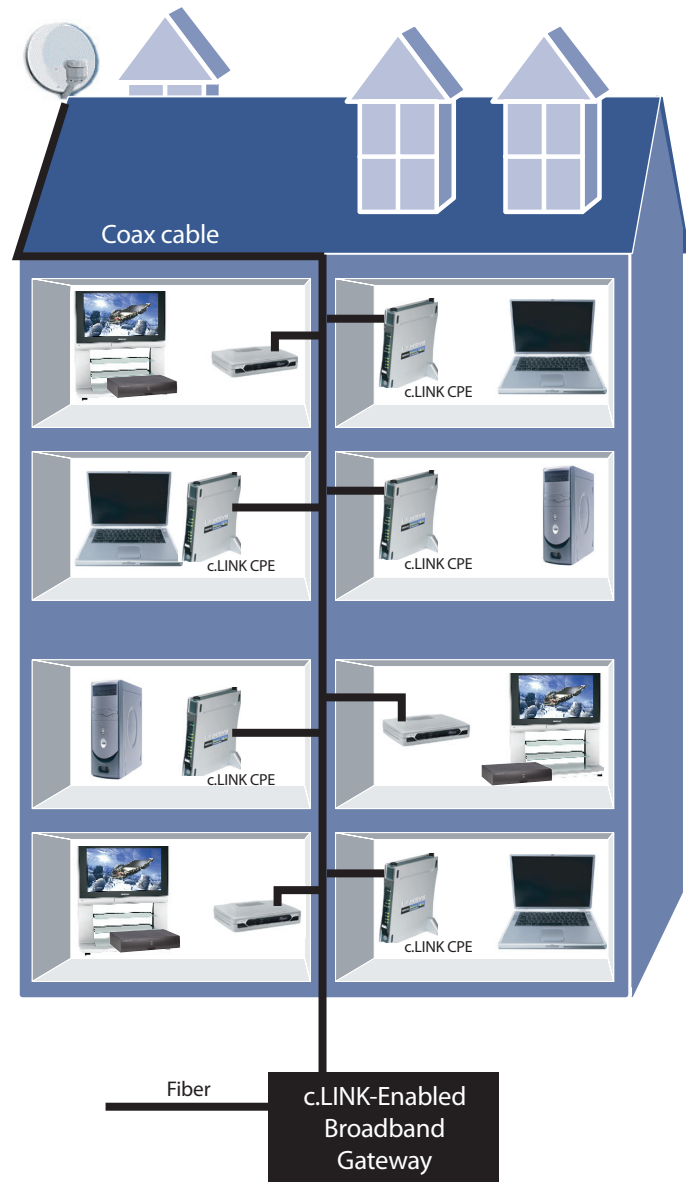

Product Reference Information

| Number | Description |
|------------|--|
| EN93010EVK | c.LINK Access Network Evaluation Kit (EVK) |
| EN93011SDK | c.LINK Linux Access Network Software Development Kit (SDK) |
| EN93230MDK | c.LINK Access Client Bridge Manufacturers Kit |
| EN1010 | Coaxial Network Interface RF Integrated Circuit - Commercial Temperature |
| EN1011 | Coaxial Network Interface RF Integrated Circuit - Industrial Temperature |
| EN3011 | Access Network Controller Integrated Circuit - Industrial Temperature |
| EN3030 | Access Client Integrated Circuit - Commercial Temperature |
| EN3230 | Next Gen Access Client Integrated Circuit - Commercial Temperature |